产品规格书

DC60 系列

第一版

深圳市中科世纪科技有限公司

深圳市宝安区福海街道福安智能制造产业园 2 栋

联系人;戴经理 18124127759

一、 产品说明 Product Description							
1) 产品名称 Part Name :		无刷直流水泵 Brushless DC Pump					
2) 型号 Model:		DC60					
3) 轴套类型 Bushing Type:		高耐磨石墨轴套 High wear-resistant graphite bushing					
4) 叶轮类型 Impeller Type:		封闭式 Closed					
4) 重量 Weight:		1.57kg					
5) 端子规格 Connector:		M16 防水接头; M16 waterproof joint					
6) 产品认证 Product certification:		CE/RoHS					
二、 产品规格参数 Product Specification							
产品型号 Model: DC60 series							
Model	Product Code	Max Water Flow (L/Min)	RatedVoltage (DC)	Rated Current (A)	Max WaterHead (M)	RatedPower (W)	Outer diameter and angle of inlet and outlet
DC60 系列 series	DC60B	53±5%	12V	4.5±8%	10±5%	80±8%	Hose type 25mm/90°
		63±5%	24V	5±6%	12±5%	120±6%	Hose type 25mm/90°
	DC60D	53±5%	12V	4.5±8%	10±5%	80±8%	Hose type 20mm/90°
		63±5%	24V	5±6%	12±5%	120±6%	Hose type 20mm/90°
	DC60E	53±5%	12V	4.5±8%	10±5%	80±8%	Thread 20mm/90°
		63±5%	24V	5±6%	12±5%	120±6%	Thread 20mm/90°
	DC60G	53±5%	12V	4.5±8%	10±5%	80±8%	Thread 25mm/90°
		63±5%	24V	5±6%	12±5%	120±6%	Thread 25mm/90°

联系人;戴经理 18124127759

三. 泵基本特征 Functional			
(标准品特点) Standard products have characteristics		(定制功能) Pump can be customized below function	
<input checked="" type="checkbox"/>	Temperature resistance 60℃	<input checked="" type="checkbox"/>	FG 信号线 FG signal feedback
<input checked="" type="checkbox"/>	潜水 Submersible pump (IP68)	<input checked="" type="checkbox"/>	电位器手动调速 VR speed control
<input checked="" type="checkbox"/>	Noise<40dB	<input checked="" type="checkbox"/>	0-5V 调速 0-5V speed control
<input checked="" type="checkbox"/>	绝缘等级 Insulation level H 级 (180°)	<input checked="" type="checkbox"/>	PWM speed control
<input checked="" type="checkbox"/>	使用寿命 Service life >30000H	<input checked="" type="checkbox"/>	PV solar pump
<input checked="" type="checkbox"/>	密封性 Sealing performance \geq 0.5 MPa (5kg)	<input checked="" type="checkbox"/>	Submersible(liquid< 60℃)
四. 产品保护功能 Protection Function			
保护功能 Protection function		具体功能描述 Specific Function Description	
<input checked="" type="checkbox"/>	卡死保护 Stuck protection	当卡住时, 水泵停止工作 When stuck, the water pump stops working.	
<input checked="" type="checkbox"/>	缺水保护 Water shortage protection	水泵因缺水而空转时, 将会反复启动和停止 When the water pump runs empty due to water shortage, it will start and stop repeatedly.	
<input checked="" type="checkbox"/>	超载保护 Overload protection	指定电压内, 电压不稳定或其他原因导致水泵额定功率超过时, 水泵停止运行。超过指定电压, 水泵将发生不可恢复的故障。When the rated power of the water pump exceeds the specified voltage due to unstable voltage or other reasons, the water pump stops running. Exceeding the specified voltage will result in irreparable failure of the water pump.	

联系人;戴经理 18124127759

☑	反接保护 Reverse protection	电源正负极反接, 水泵停止运行, 正负极正确后, 水泵正常工作。The positive and negative poles of the power supply are reversed, and the water pump stops running. After the positive and negative poles are correct, the water pump works normally.
五. 电气特性 ELECTRICAL CHARACTERISTICS:		
NO.	项目 ITEMS	规格 SPECIFICATION
1	相数. 极数 Phases. poles	3phases. 6Poles
2	12V 产品:最高操作电压 Highest operating voltage	18V
3	12V 产品:最低起动电压 Starting voltage	10V
4	24V 产品:最高操作电压 Highest operating voltage	30V
5	24V 产品:最低起动电压 Starting voltage	10V
6	工作方式 Working rated	连续 Continuous
7	距离 1 米测试噪音 Test noise at a distance of 1 meter	≤ 40 dB(A)
8	表面温度 surface temperature	< 50°C (液体/环境温度 20°C)
9	使用寿命参考 Life length	30000H
10	绝缘等级 Coil Insulation class	Class H
11	绝缘耐压强度:(Insulation endurance)	
	交流电 500 伏 60 秒与交流电 600 伏 1 秒钟, 支架与线圈之间, 漏电电流<1mA; AC500/60S or AC600V/1S between the coil and iron core ,leakage current <1mA;	
12	绝缘阻抗强度:(Insulation resistance)	
	DC500/10 兆欧姆 线圈与铁芯之间.more than DC500V/10MΩ between the coil and iron core.	
13	调速信息:	

联系人;戴经理 18124127759

	方式一:VS	0-5V 模拟电压信号, 1-5V 线型调速, 0V 停机。 5V simulation voltage signal, 1-5V linear speed regulation, 0V shutdown.
	方式二:PWM	PWM 占空比调速, PWM 频率 50-800Hz, 幅度 3-5V, 17%-100%线型调速, 0-11%停机。 PWM duty cycle speed regulation, PWM frequency 50-800Hz, amplitude 3-5V, 17%-100% linear speed regulation, 0-11% shutdown.
	方式三:VR	VR 手动电位器无级别调速, 模拟 0-5V 电压。电阻范围 4.7K~20K ;VR manual potentiometer with stepless speed regulation, simulating 0-5V voltage. Resistance range 4.7K~20K;
速度反馈 Speed feedback		
14	反馈类型	NPN, 水泵正常运行时, FG 端口输出低电频, 泵腔内无液体空转或水泵因故障不能正常工作时, FG 端口输出高电频。正负极是: P+/P-; NPN, When the water pump is running normally, the FG port outputs a low electrical frequency. If there is no liquid idling in the pump chamber or the water pump cannot work normally due to a malfunction, the FG port outputs a high electrical frequency. The positive and negative poles are: P+/P -;
	反馈方式	三极管集电极无源输出, 转速脉冲信号, MCU 转输信号, 反馈频率, 频率的 30 倍为实时转速。Passive output transistor collector, speed pulse signal, microcontroller transmission signal, feedback frequency, 30 times the frequency is real-time speed.

联系人;戴经理 18124127759

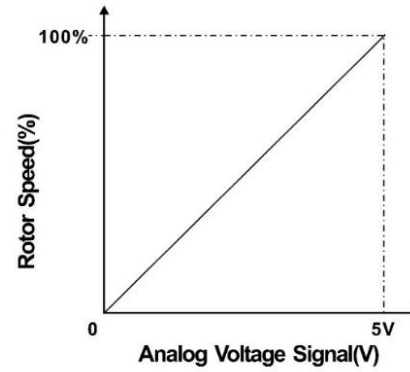
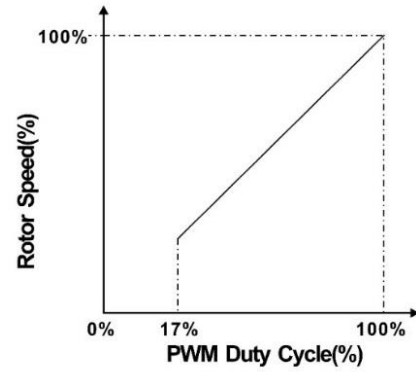

六. 安装示意图 Installation diagram

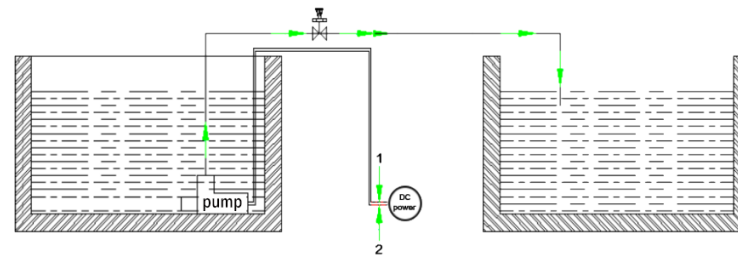

潜水安装

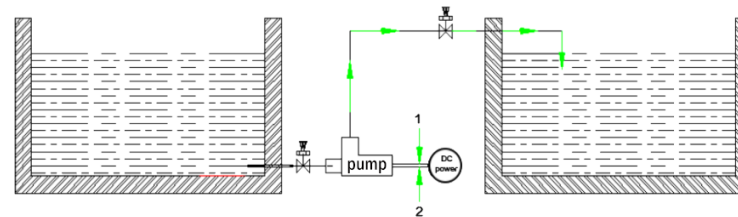

非潜水安装

注意: 本产品不具备自吸功能, 因此在安装时, 需要保证压盖型腔内具有足够的水, 即安装时需要保证水泵中心位置低于水箱内液面, 以保证水泵能够正常运行! Attention: This product does not have a self suction function, so during installation, it is necessary to ensure that there is sufficient water in the gland cavity. That is, during installation, it is necessary to ensure that the center position of the water pump is lower than the liquid level in the water tank to ensure that the water pump can operate normally!

七. 使用范围 Application Conditions

联系人;戴经理 18124127759

1	使用环境温度 Environment temperature	-30~ 40℃
	使用液温 The use of water temperature (high temperature version)	-30~ 100℃
	使用液温 The use of water temperature (standard version)	-30~ 70℃
2	使用环境湿度 Operation Surroundings	100%(所有有机种)
3	使用溶液 Working liquid	Pure water, antifreeze, other
4	防尘防水等级 IP Level	IP68
5	极限压力 Max pressure / 长期承压 Continue work Pressure	0.7 Mpa / 0.4 MPa
6	存储温度/湿度 Storage temperature/humidity	<80%RHat25℃ / 70%RHat40℃

八. 产品材料 Materials

部件 Parts	材料 Material	部件 Parts	材料 Material
压盖 Gland	PP black +30%GF	泵体 Pump body	PPS black +30%GF
后盖 Rear cover	PP black +30%GF	转子 Rotor	PP+GF
磁铁 rotor magnet	铁氧体 Ferrite	密封圈 Seal ring	EPDM
轴芯 Axis core	陶瓷 Ceramics	轴套 Bearing sleeve	石墨 Graphite

DC60B 泵头 Pump Head DC60B

联系人;戴经理 18124127759

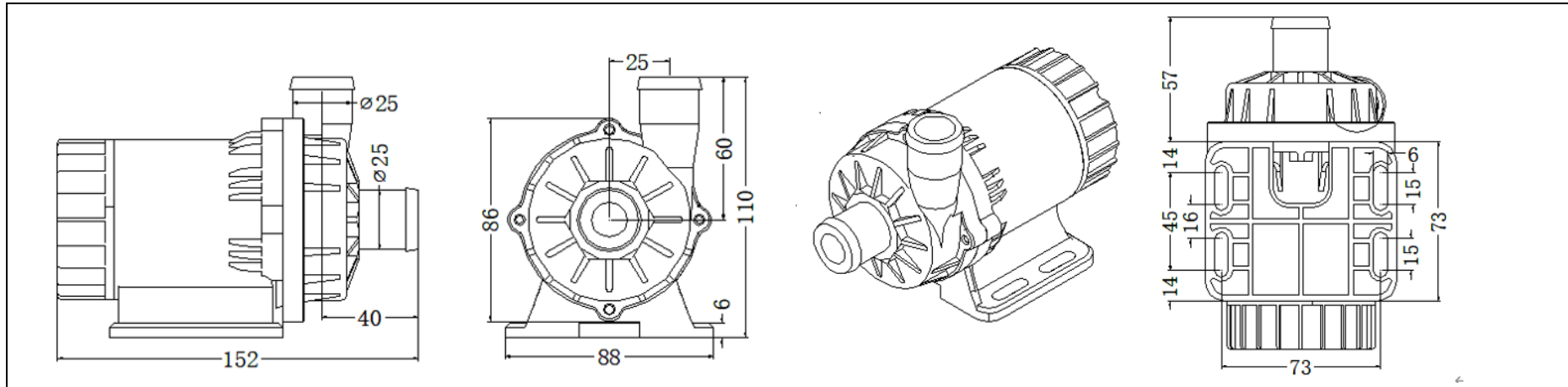

DC60D 泵头 Pump Head DC60D

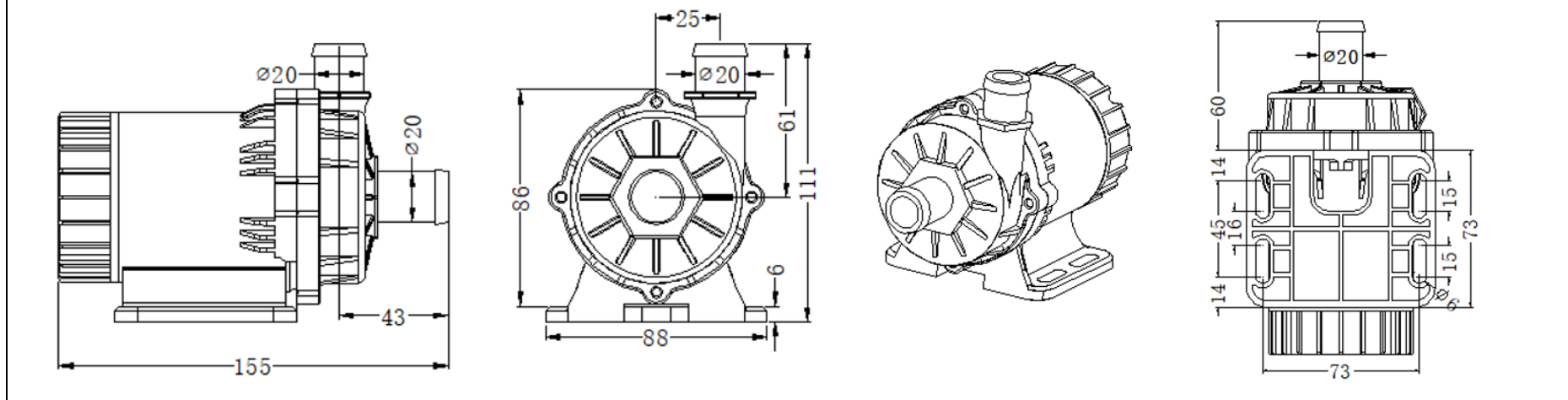

DC60E 泵头 Pump Head DC60E

联系人;戴经理 18124127759

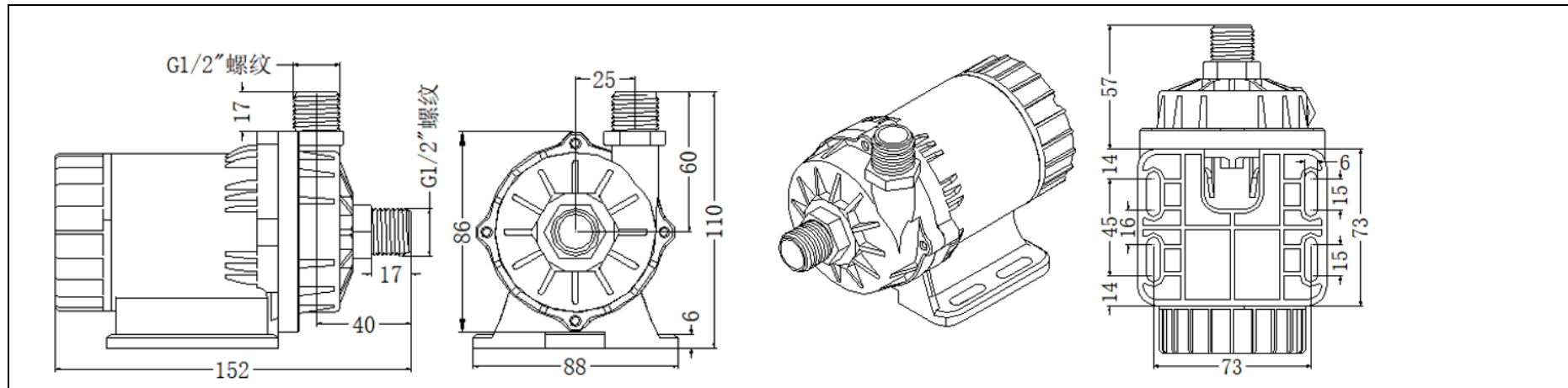

DC60G 泵头 Pump Head DC60G

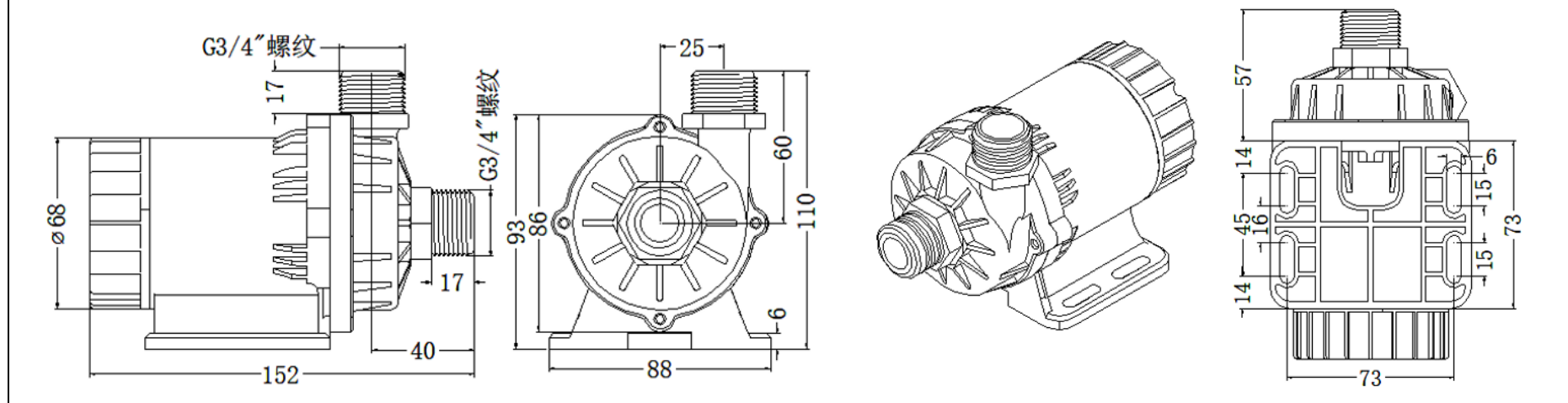

水泵驱动内外置版本图解 Diagram of internal and external versions of water pump driven.

联系人;戴经理 18124127759

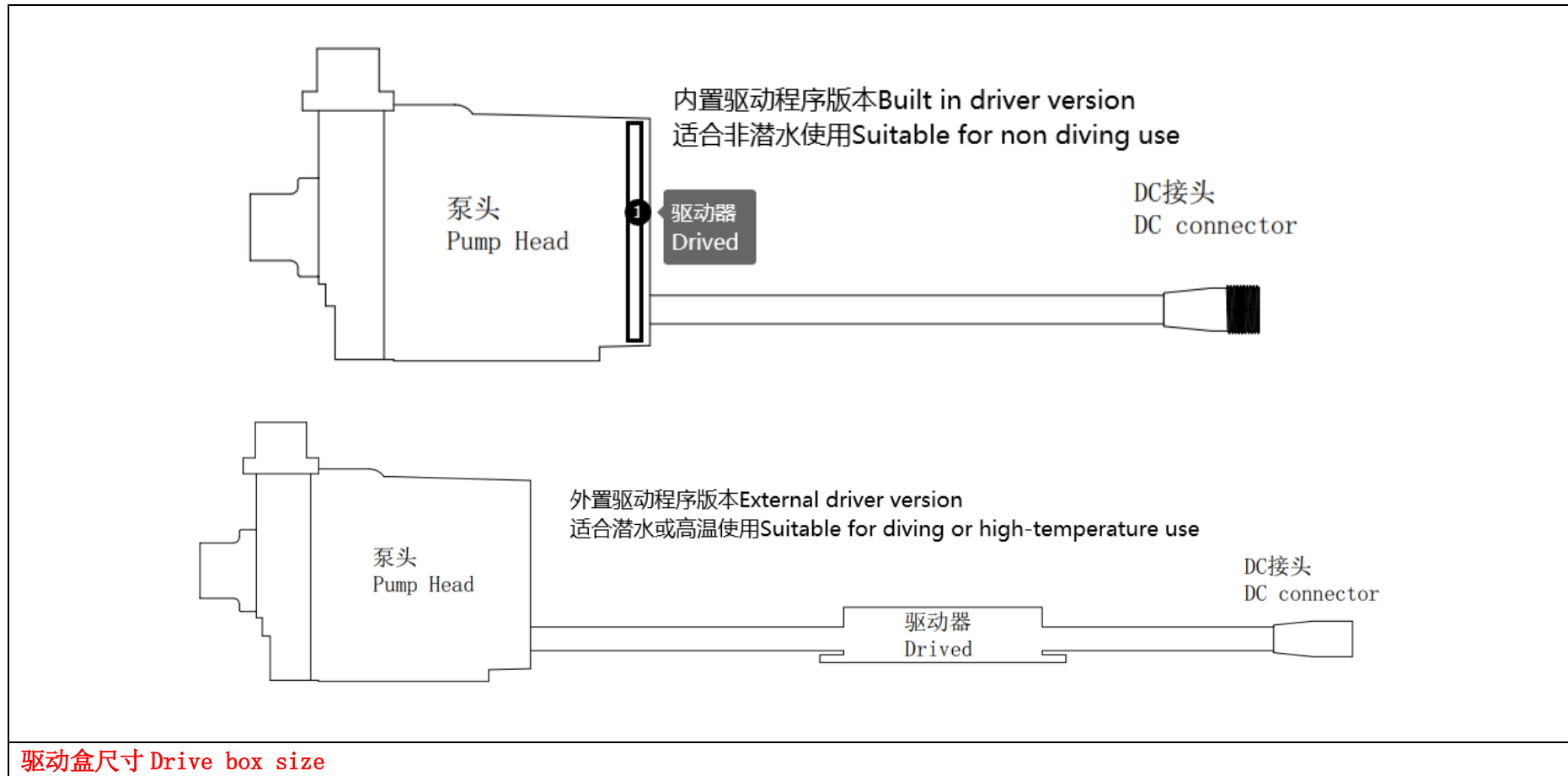

联系人;戴经理 18124127759

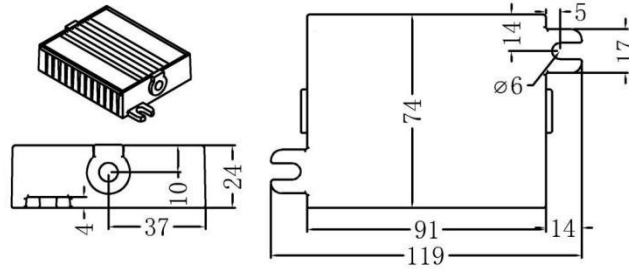

九. 曲线 Curve

联系人;戴经理 18124127759

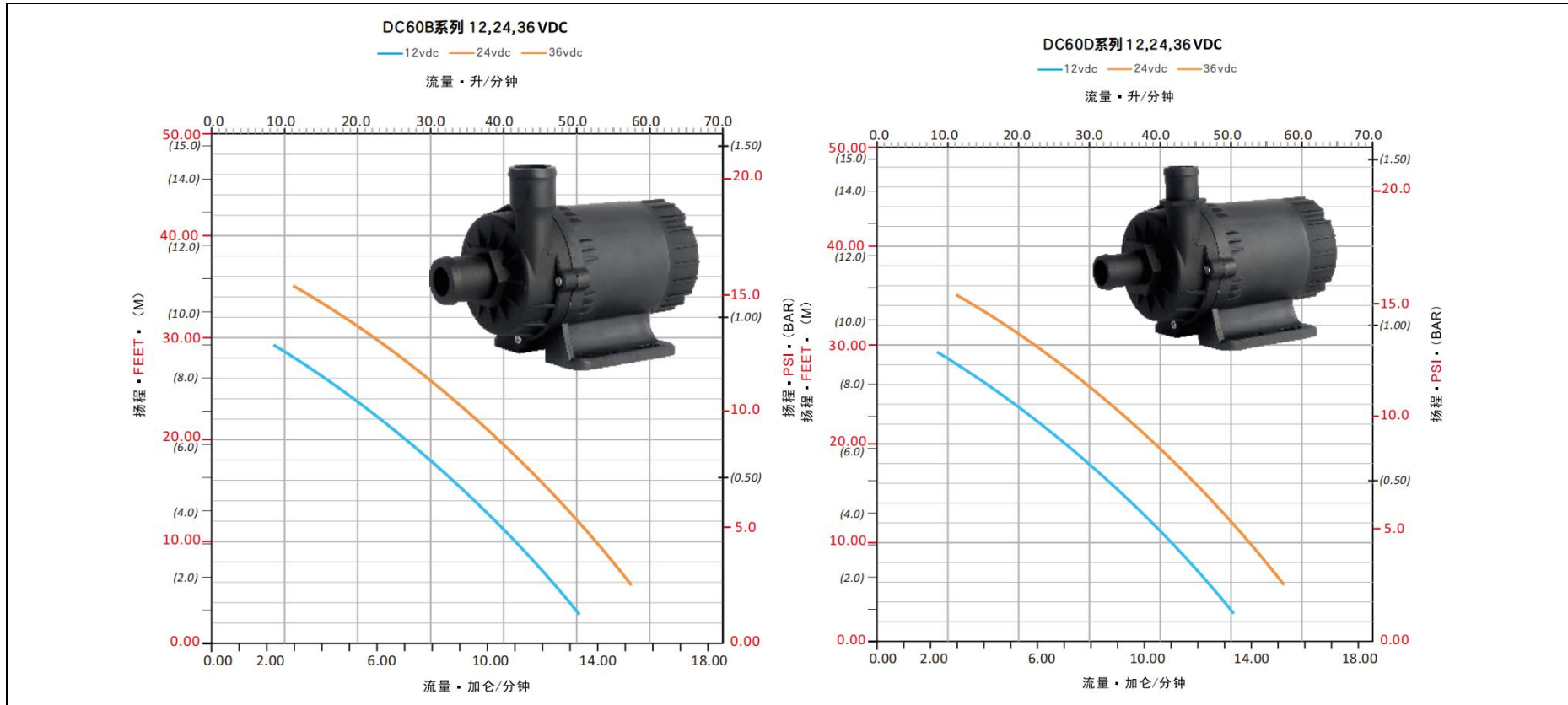

联系人;戴经理 18124127759

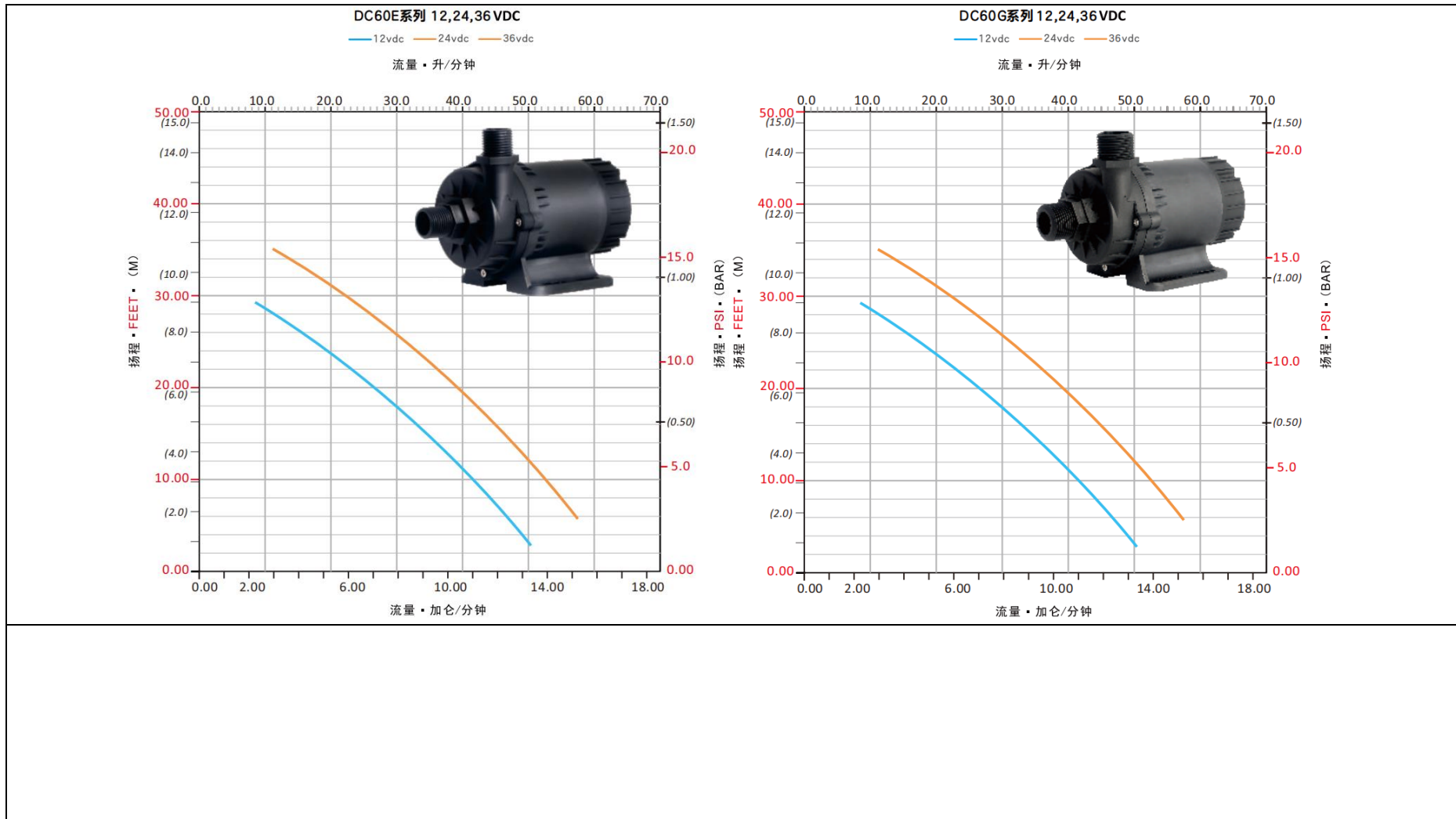

联系人;戴经理 18124127759

十. 故障与维修 Faults and Maintenance			
	故障现象 Fault phenomenon	原因 Cause of malfunction	解决方案 Solution
1	电流大, 流量小; High current, low flow	转子内有杂质; Impurities inside the rotor	拆开水泵清洗转子; Disassemble the water pump to clean the rotor
2	电流变小, 抽水断续; The current decreases and the pumping is intermittent	缺水 Water deficient state	补充液体 Supplementing liquids
3	不转, 电流时大时小; Not rotating, current varies between high and low	转子因异物卡死 The rotor is stuck due to foreign objects	排除转子卡死异物 Exclude foreign objects stuck in the rotor
	不转, 出现短路电流; No rotation, short circuit current occurs	控制板损坏 Control board damaged	更换水泵 Replace the water pump
	不转无电流; No rotation, no current	电源线没有接好 The power cord is not properly connected	检查连接件或插头是否正常 Check if the connectors or plugs are functioning properly
4	噪音大; High noise level	泵内有杂质 Impurities inside the pump	排除杂质 Excluding impurities
		泵内有气体无法排出 There is gas inside the pump that cannot be discharged	将出水口朝上放置, 使液体中没有空气 Place the water outlet facing upwards so that there is no air in the liquid
		泵内无液体, 水泵干磨; There is no liquid inside the pump, and the water pump is dry ground	使泵内有液体即可; Just make sure there is liquid inside the pump